



CHAMBER OF COMMERCE  
ECONOMIC DEVELOPMENT AGENCY  
S A N M A R I N O



Republic of San Marino  
Official Business Gate

# Design, sfida tecnica e culturale per conoscere e competere

Elena Brigi \_ricercatrice\_ UniRSM Design

17.04.2024



Living with Complexity  
Donald A. Norman

## Complexity

Il buon design può aiutarci a dominare la complessità, non rendendo le cose meno complesse (perché la complessità è necessaria), ma gestendo la complessità.

Perché abbiamo bisogno della complessità?  
Perché il mondo è complesso e come posso dominare la complessità? La risposta è con il design.

Donald Norman, Living with Complexity, MIT Press, 2011



Design \_ un fatto quotidiano .....  
accompagna le nostre giornate



Naoto Fukasawa, Wall Mounted,  
lettore CD a parete, Muji, 1999



**Design \_ un fatto quotidiano .....**  
indossiamo

**Issey Miyke, steam stretch, abito**  
collezione autunno-inverno 2004



*Tubu-tubu*



*Sube-sube*



*Zava-zava*



*Loge-loge*



*Goro-goro*



*Fuwa-fuwa*



*Poki-poki*



*Suka-suka*



*Zaku-zaku*

Design \_ un fatto quotidiano .....delizia

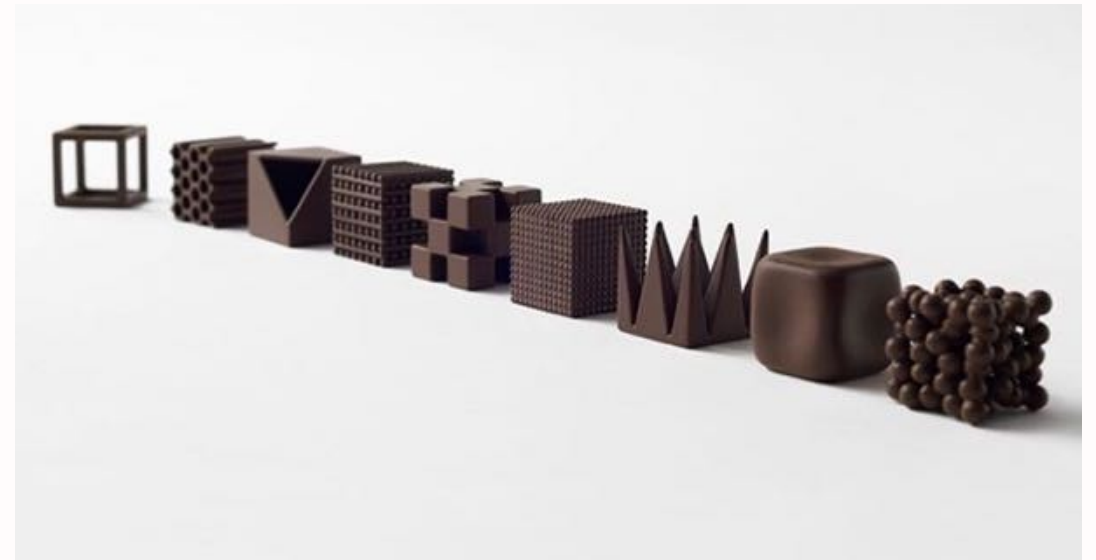

NENDO / Oki Sato, chocolatexture, Parigi 2015



Design \_ un fatto quotidiano ..... nel lavoro



New RKK, torn a tunnel per la cottura della ceramica sanitaria, Isao Hosoe e Lorenzo De Bartoleis e Emilio Cassani, Sacmi Forni, Italia 2004-06



**Design \_ un fatto quotidiano  
..... nel trasporto**

**ITALO NTV**  
Alstom e Italdesign Giugiaro, 2011



Design \_ un fatto quotidiano ..... salva la vita



**Humulin Insulin Pen**, prima penna per insulina  
**NovoLet**®, siringa monouso per insulina, Steve  
McGugan, Novo Nordisk A/S 1995

Design \_ un fatto quotidiano ..... protegge

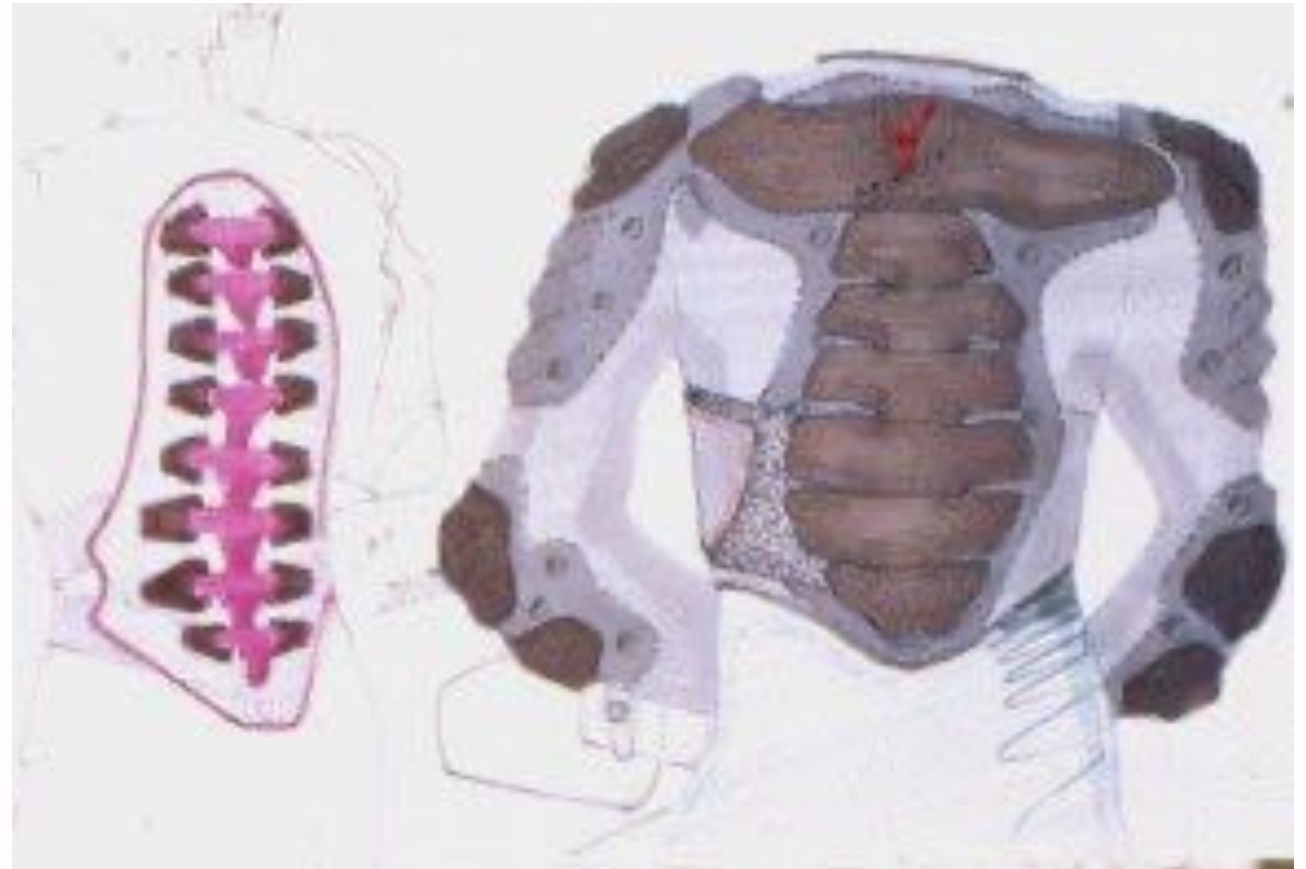

Bap, safety jacket, Marc Sadler, Dainese, 1992

Design \_ un fatto quotidiano ..... aiuta le persone



Leveraged Freedom Chair (LFC)



**Design \_ industria**

**Dante Giacosa, nuova 500  
FIAT, 1957**



## Design \_ case history



Adriano Olivetti, Ivrea anni '50



Negozio Olivetti, BBPR,  
New York 1950



**Design \_**  
l'importanza degli archivi

**Pier Giacomo e Achille Castiglioni**  
Fondazione Castiglioni, Milano

# Design \_ comunicazione

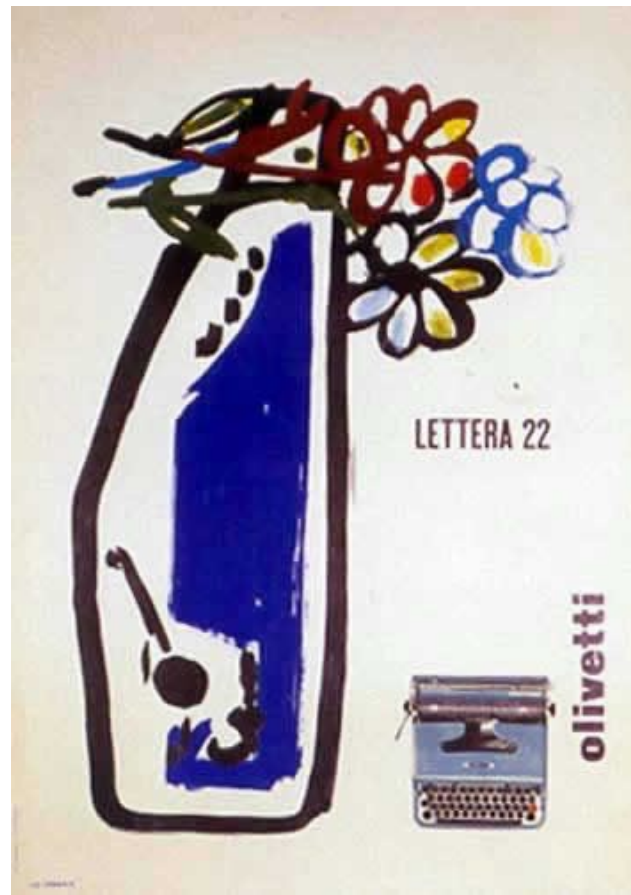

Giovanni Pintori, Olivetti, Lettera 22, manifesti 1952-53





## Design \_ produzione

La produzione è il mezzo di comunicazione più efficace del nostro tempo, un mezzo che può essere utilizzato come veicolo di stupidità o di civiltà.

La macchina che produce si configura così come un'arma meravigliosa o terribile e chi ne dispone ha il dovere di capire che cosa sta facendo.

Dino Gavina, 1969

Design \_ i bisogni della gente



Lanzavecchia + Wai - Together Canes

**LESS  
BUT  
BETTER**



## I designer \_ pensieri, strategie, progetti

### Dieter Rams \_ 10 principi del Good Design

- Un buon design è innovativo
- Un buon design rende un prodotto utile
- Un buon design è estetico
- Un buon design rende un prodotto comprensibile
- Un buon design è discreto
- Un buon design è onesto
- Un buon design è di lunga durata
- Un buon design è accurato, fino all'ultimo dettaglio
- Un buon design è ecologico
- Un buon design è il meno possibile la progettazione

# I designer \_ pensieri, strategie, progetti

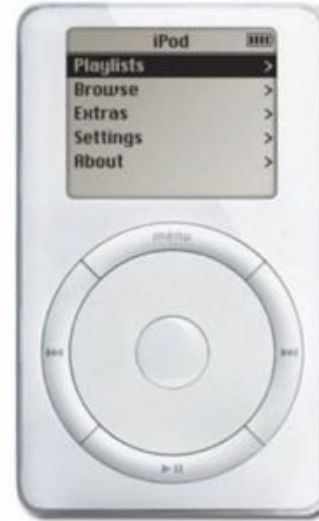

**Jonathan Ive**

“... design is the most immediate,  
the most explicit way of defining what  
products become in people’s minds”

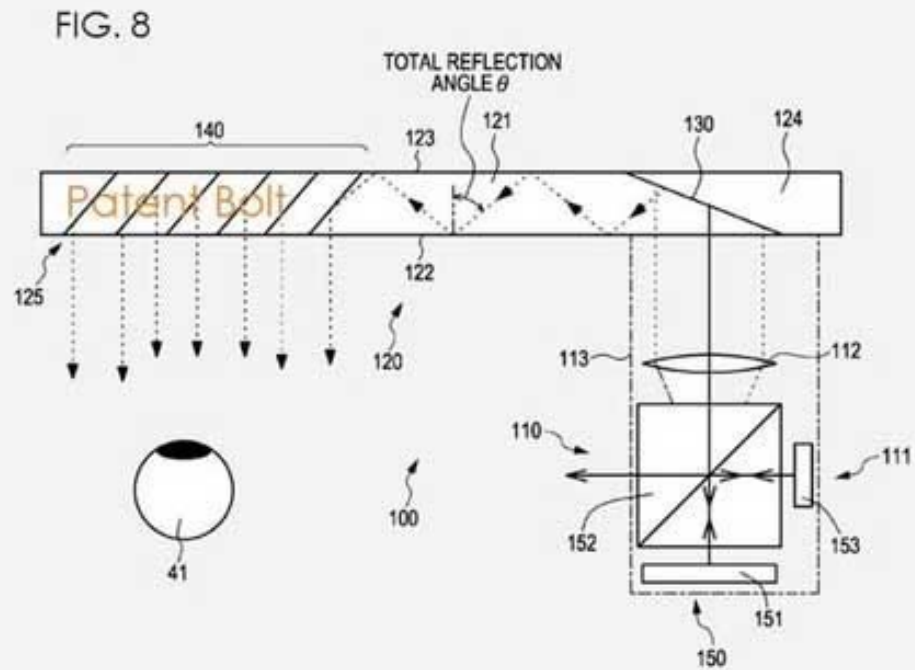
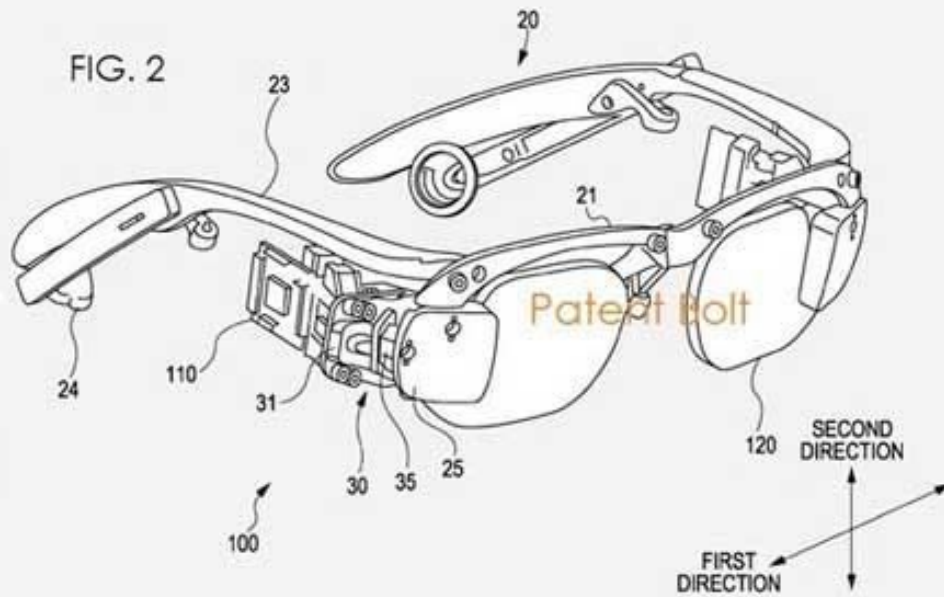

Design \_ una ricerca continua



Google glass, 2014

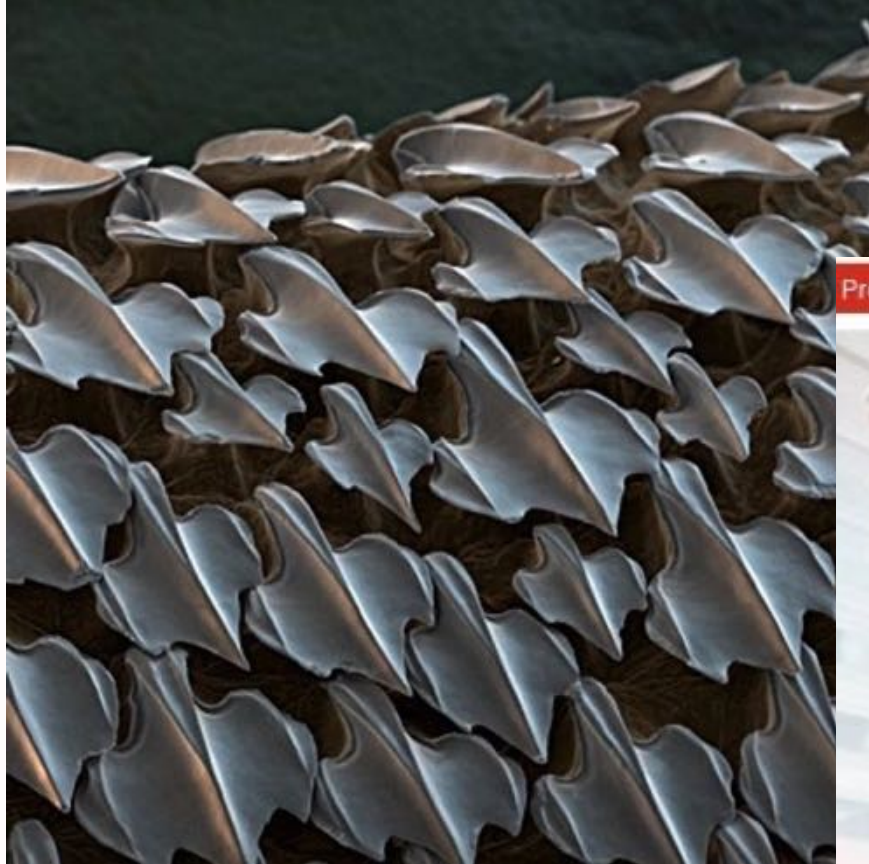

## Design \_ le nuove tecnologie

i brevetti del nuovo millennio \_ le nanotecnologie e la ricerca dei record

[Prodotti](#) | [Innovazioni](#) | [Sport](#) | [Storia](#) | [Novità](#) | [Rivenditori](#) | [Shop](#)

29 settembre 2008 | [Re](#)

100.000 ANNI DI EVOLUZIONE  
80 ANNI DI SVILUPPO  
14 ANNI DI ALLENAMENTO  
E TUTTO CIÒ CHE CONTA  
SONO I PROSSIMI...

1:43.86

MICHAEL PHELPS  
23 volte Record del Mondo

FASTSKIN

LZR RACER

[I nostri valori](#) | [Global Home](#) | [Notizie legali](#) | [Regole sulla privacy](#) | [Termini e condizioni](#) | [Contattaci](#)

Pelle di pescecane vista attraverso le lenti di un microscopio nanometrico.

Michael Phelps e SPEEDO LZR RACER, 2008

# Design \_ i brevetti e la protezione dell'innovazione

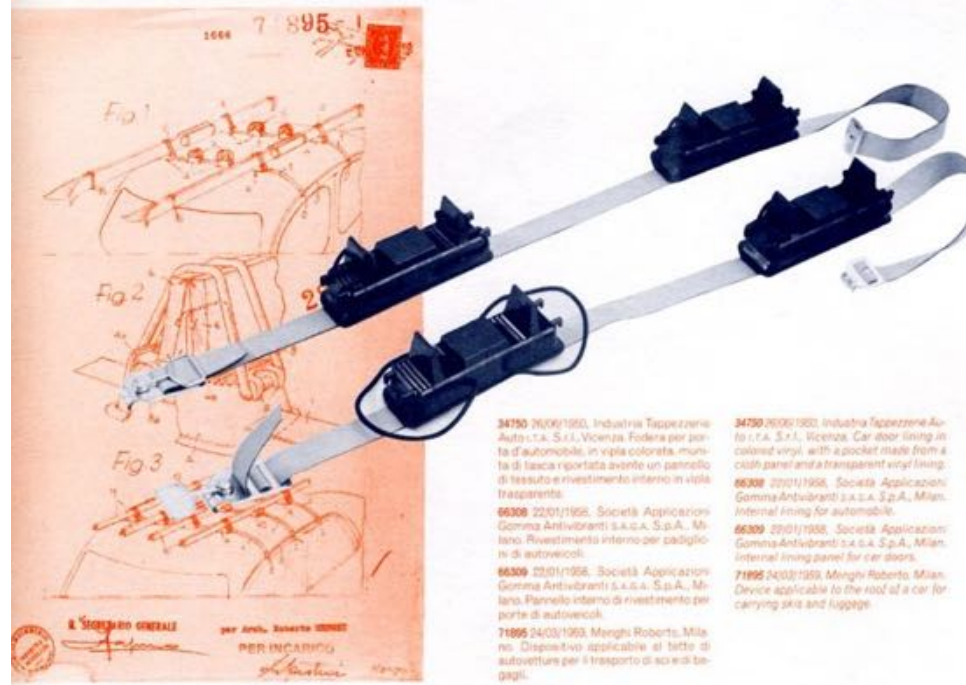
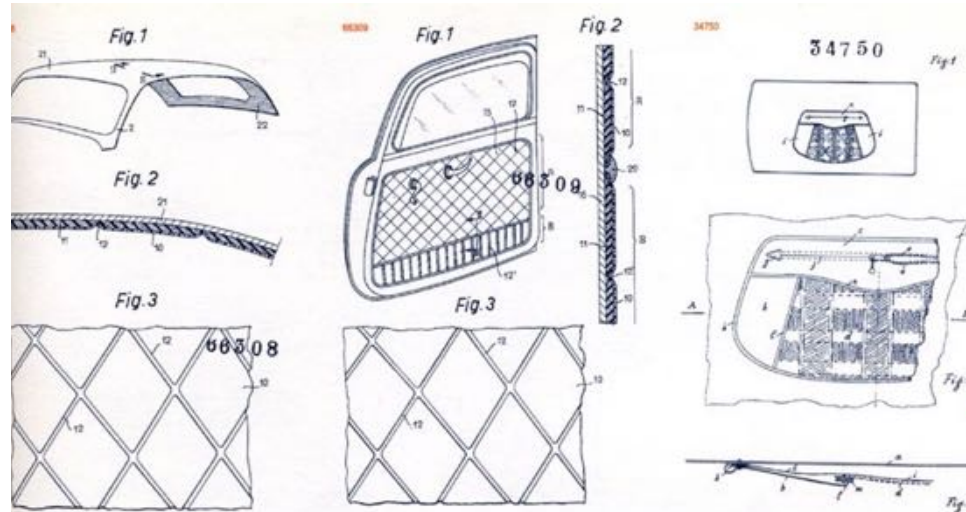

1959, Roberto Menghi  
cinghie elastiche per sci e  
bagagli, brevetto n. 71895





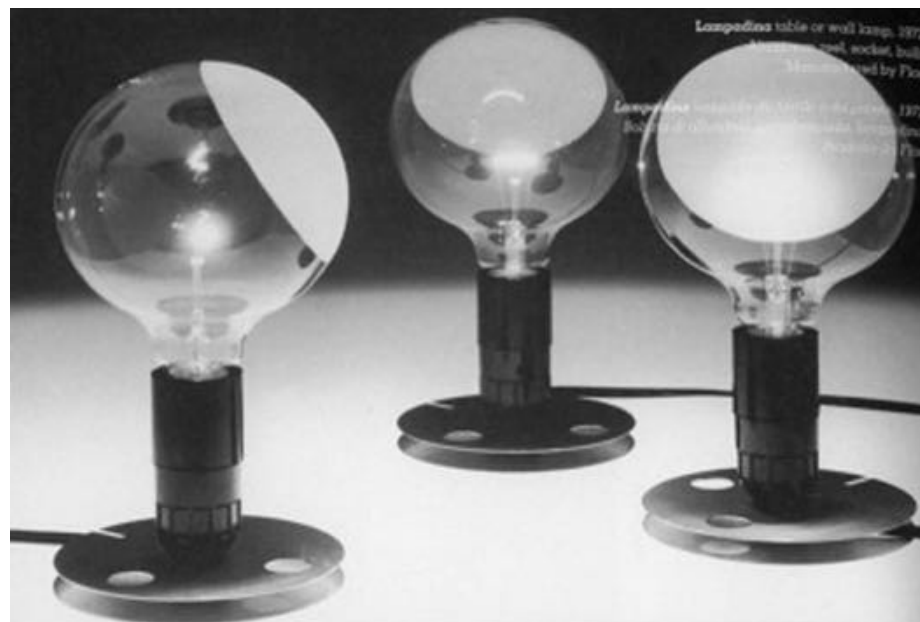

metodo 'Castiglioni', la non riconoscibilità



metodo Starck, riconoscibilità tout-court